

**Kyoto Breast Cancer Consensus Conference  
2020  
International Convention  
(KBCCC2020 International Convention)  
Sponsor, Advertiser and Exhibitor Guideline**

Date: April 2(Thur.), 3 (Fri.) and 4(Sat.), 2020

Venue: Kyoto International Conference Center

<https://www.kyoto-breast-cancer.org/international/2020/index.php>

## Table of Contents

### 1. Summary

•Greeting .....	3
•Convention Outline.....	4

### 2. Sponsor Guideline

•List of Sponsoring Options.....	6
•Seminars and Sessions .....	6
•Application and Payment.....	8

### 3. Display

•Exhibition Guideline .....	9
•Application and Payment.....	11

## Greetings

Dear Sir/Madam,

We are pleased to announce “Kyoto Breast Cancer Consensus Conference 2020 International Convention” to be held on April 2(Thur.), 3 (Fri.) and 4(Sat.), 2020 at The Kyoto International Conference Center.

In Japan we have had regular meetings discussing individual themes since October 2007 and the meeting held in May this year marked the 30th such meeting.

As for the International Conventions; the first convention was held in April 2009 and saw professors and experts gathering from all over the world which far exceeded the expected numbers of the organizing team. The second conference was held right after the earthquake and tsunami in the north east of Japan. Many professionals and experts got together once again and it was an extremely meaningful convention in order to aim for the formation of a consensus regarding methods of treatment/diagnosis.

Next year’s “Kyoto Breast Cancer Consensus Conference 2020 International Convention” will involve in reviews of the latest movements and we are hoping to consider the current consensus.

We are in the preparation of holding a meaningful convention academically as well as a forum for international exchange.

Myself personally, I will prepare for and run the meeting as the representative chair of the Organizing Committee. I would like to inform companies/groups to which I am indebted for daily assistance about this convention and to take such a global scale convention as an opportunity to introduce your products and your activities as well as a place to share knowledge with the convention participants.

Yours faithfully

Professor Masakazu Toi M.D Ph.D

Representative Chair of KBCCC 2020 International Convention

Breast Surgery Department, Graduate School of Medicine, Kyoto University

## Convention Outline

✧ Convention Dates

April 2(Thur.), 3 (Fri.) and 4(Sat.), 2020

✧ Venue

Kyoto International Conference Center

Takaragaike, Sakyo-ku, Kyoto 606-0001 Japan TEL: +81-75-705-1251

URL: <https://www.icckyo.or.jp/en/visitor-2/access/>

✧ Name of hosting institution

Kyoto Breast Cancer Consensus Conference 2020 International Convention

Representative Chair (Facilitator) Professor Masakazu Toi (Breast Surgery Department, Graduate School of Medicine, Kyoto University)

✧ Purpose and significance of the academic convention

The purpose of holding the convention is to achieve a consensus on treatment of breast cancer and to strive for better treatment results. Various guidelines which have been published to date or contents which have been considered at other international conferences do not always touch on the detailed parts of the current situation and decisions that are made are rely on the judgment of the receivers. At this convention we aim to unify such recognition and implement activities as the KBCCC group. The purpose of the meeting is to spread out international standards of breast cancer treatment from Kyoto.

✧ Outline of the plans of the conference

(1) Main Theme

Novel Paradigm of Immuno-oncology

Multidisciplinary Treatment for Favorable Responders

Optimal Screening Planning

(2) Framework of academic program

Invited lectures, panel sessions, consensus sessions, poster presentation

(3) Main sessions of the convention

- Immuno-oncology in breast cancer
- New diagnostics and therapeutics
- Novel aspects, issues and perspectives in local management
- Qualification and quantitation of treatment outcomes, Quality of Life (QOL)
- Algorithm: How to select the optimal systemic therapy and local therapy

Germline assays and risk assessment

Genomic abnormalities, HRD

RNA assays

Protein assays

Liquid biopsy

TILs

Immune signatures

Others

- DCIS

(4) Number of prospective turnout

Domestic participants 200 people

Overseas participants 200 people

(5) Convention URL

<http://www.kyoto-breast-cancer.org/jp/>

✧ Inquiries regarding this conference

Kyoto Breast Cancer Consensus Conference Secretariat

ParkHomes Sagaarashiyama-Sakuratei308

43-1 Sagashinguumachi, Ukyo-ku.

Kyoto City 616-8355 Japan

TEL : 075-600-8675

FAX : 075-320-2575

E-mail:info@kyoto-breast-cancer.org

✧ Other

If you have an interest in supporting this conference please feel free to contact the KBCCC 2020 International Convention Secretariat.

## Sponsorship Options

### 1. Symposium

\*Submission deadline (scheduled): December 31 2019

Co-Organized Session/Seminar	Time/Number of prospective turnouts	Cost	Number of applications
Morning Seminar	30~60min•About 400 people	1,500,000yen	2
Afternoon Seminar	30~60min•About 400 people	2,500,000yen	3
Evening Seminar	30~60min•About 400 people	2,500,000yen	4

(\* Exclusive of consumption tax)

### 2. Insertion of Advertisement into Printed Matter

\*Submission deadline (scheduled): January 31 2020

- Program (Number of prospective publication: 600)

KBCCC 2020 Program, which will include the convention program, social events and general information, will be circulated to all participants. Please note the design fee is not included in the below insertion cost.

Media creation cost: 1,125,000yen (exclusive of tax, planned)

Program abstract	Size	Insertion cost	Num. of applications
Back side of the front cover (1 page in color)	A4 whole page (W180mm x H277mm)	550,000yen	1
Back side of the back cover (1 page in color)	A4 whole page (W180mm x H277mm)	275,000yen	1
Black and white (1/2 page)	A4 1/2(W180mm x H120mm)	78,750yen	5

Size negotiable (\* exclusive of consumption tax)

[Advertisement text] PDF file

**English text recommended** as this is an international conference. (Japanese allowed)

### 3. Various services within the venue

\* Submission deadline (scheduled): December 31,2019

- Coffee breaks

5 times (scheduled) per day during the convention period. Coffee, tea, and refreshment will

be provided to the participants. Coffee price etc will be included in the cost below.

However, we may charge an extra fee for additional items etc.

Coffee break Insertion into Program abstract book and refreshment offering space	Time	Cost	Number of application
Day 1 April 2(Thur.),2020	TBA	2,200,000yen	1
Day 2 April 3(Fri.),2020	TBA	2,200,000yen	1
Day 3 April 4(Sat.),2020	TBA	1,100,000yen	1

(\* Exclusive of consumption tax)

## 4. Promotional Goods

\* Submission deadline (scheduled): December 31, 2019

- Congress bag (Planned number of production: 600)

Bags will be given to all participants. Your company's name will be impressed not just during the convention but after the convention too.

For congress bags, the logo of the applicant company as well as the logo of KBCCC 2020 will be inserted. For change of design or change of specification, we will charge an extra fee.

Congress bag	Size of logo	Cost	Number of applicants
Printed on the congress bag (black and white)	<b>25mm×25mm</b>	<b>55,000円</b>	<b>5</b>

(\* Exclusive of consumption tax)

[Advertisement text] Adobe Illustrator Data, PDF file

- Name card holder (Number of prospective offerings: 600)

Name card holders will be given to all participants. Your company's name will be impressed not just during the convention but after the convention too. Name card holders are printed with either name or logo of the sponsor company.

Name card holder	Cost	<b>SOLD OUT</b>
Advertisement fee	<b>88,000yen</b>	

(\* Exclusive of consumption tax)

[Advertisement text] Illustrator data, PDF file

- Participation certificate (Prospective number of production: 600)

Participation certificates will be given to all participants. Your company's name will be impressed not just during the convention but after the convention too. Participation

certificates are published with the logo of the sponsor company. For change of design or change of specification, we will charge an extra fee.

Participation certificate	Size of logo	Cost	Number of applicants
Printed on the participation certificate (in color)	18mm×18mm	33,000yen	5

(\* Exclusive of consumption tax)

[Advertisement text] Illustrator data, PDF file

- Other

Please feel free to consult with the KBCCC2020 International Convention Secretariat if you have any other means to offer support other than above.



## **Application and Payment**

Kyoto Breast Cancer Consensus Conference 2020 (KBCCC2020) Secretariat will sign the contract with each company as the representative of the steering committee. All sponsors' applications will be accepted in a first-come-first-served order. In general rule we cannot accept applications after the submission deadline.

### **Method of application**

Please fill out the required fields in the attached application form and send it by FAX or Email to the address below.

Kyoto Breast Cancer Consensus Conference Secretariat  
ParkHomes Sagarashiyama-Sakuratei308  
43-1 Sagashinguumachi, Ukyo-ku.  
Kyoto City 616-8355 Japan  
TEL : 075-600-8675/FAX : 075-320-2575, E-mail:info@kyoto-breast-cancer.org

\* Please make sure to write down your company's name using Roman alphabet as the English name will be required at the time of inserting the name in the program. The name will be published as it is written in the application form so please be advised to be careful of any mistakes. (Upper case and lower case will be published as written in the application form). \* We will contact the person who is specified as the contact person in charge in the form. Should you wish to change of contact person in charge, please let the conference Secretariat know as early as possible.

### **Method of payment**

Please make all payments in Japanese yen. After receiving the application form, you will be issued an invoice from the secretariat. Please make payment of the sponsoring charge to the designated account by the payment deadline date specified in the invoice. Please incur any bank transfer fees at your expense.

### **Cancelation**

In the case of canceling; please contact the Secretariat as soon as possible.  
Cancelation costs are as below.

October 10, 2020 – January 1, 2020: 30% of fee of application

January 2 – March 1, 2020: 50% of fee of application

March 2- April 1, 2020: 100% of fee of application

### 3. Display

#### ✧ Exhibition Outline

A KBCCC 2020 exhibition will be held with many overseas visitors as well as domestic visitors expected so this will be an excellent advertising opportunity for applicant companies. In order for the convention participants to be enticed to visit the display area, we are planning to hold coffee breaks and a poster exhibition within the convention venue site. Application will be received on a first-come-first-served basis. [Submission deadline: Monday 27 Jan 2020]

**Conference date:** April 2(Thu.)-April 4 (Sat.) 2020

**Exhibition Venue:** Kyoto International Conference Center

**Schedule:** Carry-in articles:April 1(Wed.) 2020 PM-/Carry-out articles:April 4 (Sat.) 2020 PM-

\*We will inform you of the exact details at a later date

#### 1. Display charge and the specification of exhibition stand

##### • Display charge

	Type of booth	Unit	Size	Cost	Exhibitor boards
1	Space stand		W1800m × D900mm	55,000yen	2
2	Basic stand		W1800m × D900mm	275,000yen	2

(\* 消費税を含まない)

1) Space stand: (1) The size of stand frontage 1800mm x Depth 1800mm

•The cost includes

- Exhibition space
- Publishing the name of the company in the program abstract book
- Exhibition table as well as chairs will be arranged at extra cost

2) Basic stand: The cost includes

(1)The size of stand frontage 1800mm x Depth 900mm x Height 2100mm

(2)The basic interior for the stand is fabricated paper finish (white) for back and side panels.

In the case of specifying the color, there will be an extra charge.

(3) Company's name board will be made for free of charge by the secretariat.

The text will be in gothic alphabet by 'sumi' ink. In the case of specifying logo, color and delimiters, these can be done at extra cost.

(4) Spotlights (2 sets of lights of 100w)

2 chairs and exhibition desk (table) will be arranged free of charge.

(5)All other work other than the above, such as décor will all be at the expense of the exhibitor.

(6) Insertion of the company name into the program abstract book.

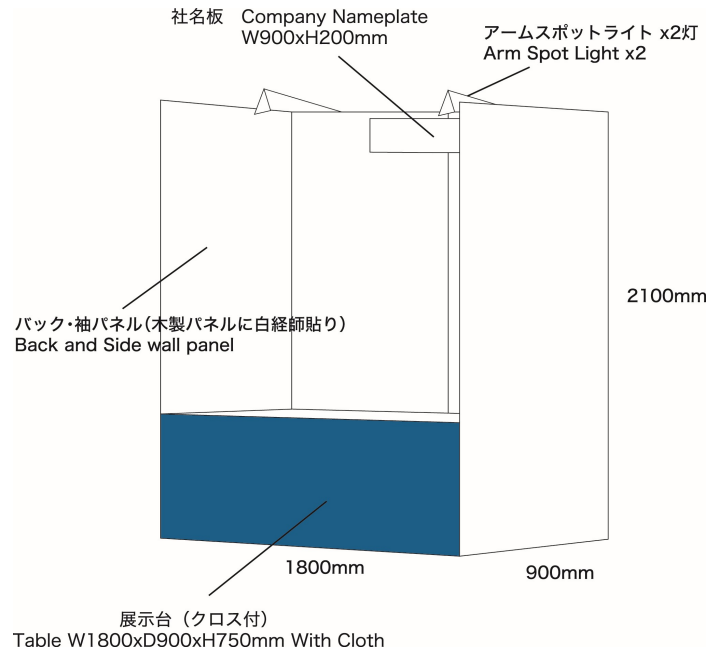

## 2. Number of exhibitors

- 10 stands (scheduled)
- The allocation of display stands will be coordinated and decided by the host.

## 3. Management of exhibition venue

The display committee is doing their best for the management of exhibition items and exhibition venue area however they cannot be responsible for any losses by theft, accident or natural disasters etc.

## 4. Change of conference session date, time or venue

The conference date, time or venue is subject to change due to inevitable circumstances. Cancellation of display for such changes cannot be permitted. Also the conference will not be responsible for any losses which occur from these changes.

## **Application and Payment**

Kyoto Breast Cancer Consensus Conference 2020 International Convention Secretariat will sign the contract with each company as the representative of the steering committee. All sponsors' applications will be accepted in a first-come-first-served order. As a general rule we cannot accept applications after the submission deadline.

### **Method of application**

Please fill in the required fields in the attached application form and send it by FAX or Email to the below.

Kyoto Breast Cancer Consensus Conference 2020 Secretariat

ParkHomes Sagaarashiyama-Sakuratei308

43-1 Sagashinguumachi, Ukyo-ku.

Kyoto City 616-8355 Japan

TEL : 075-600-8675/FAX : 075-320-2575, E-mail:info@kyoto-breast-cancer.org

\* Please make sure to write down your company's name in Roman alphabet as the English name will be required at the time of inserting the name into the program. The name will be published as it is written in the application form so please be advised to be careful of any mistakes. (Upper case and lower case will be published as written in the application form). \* We will contact the person who is specified as the contact person in charge in the form. Should you wish to change the contact person in charge, please let the Secretariat know as early as possible.

### **Method of payment**

Please make all payments in Japanese yen. After receiving the application form, the Secretariat will issue an invoice. Please make payment of the sponsoring charge to the designated account before the payment deadline specified in the invoice. Please incur any bank transfer fees at your expense.

### **Cancellation**

In the case of canceling the display for which you have applied, please contact the Secretariat. Cancellation costs are as follows:

October 10, 2020 – January 1, 2020: 30% of fee of application

January 2 – March 1, 2020: 50% of fee of application

March 2- April 1, 2020: 100% of fee of application